

ARKIMEDE 60 - DECKING



INDEX

1. Code Registry
2. Description
3. Use
4. Fields of use
5. Load test
6. Technical specification

1. CODE REGISTRY

| Code | Description | Dimension (mm) | Weight (kg) | Pkg. / Pallet |
|-------|---------------------|----------------|-------------|--------------------|
| 30536 | ARKIMEDE 60-Decking | from 60 to 115 | 0,24 | 30 pcs. / 450 pcs. |

MATERIAL Made of PP (polypropylene).

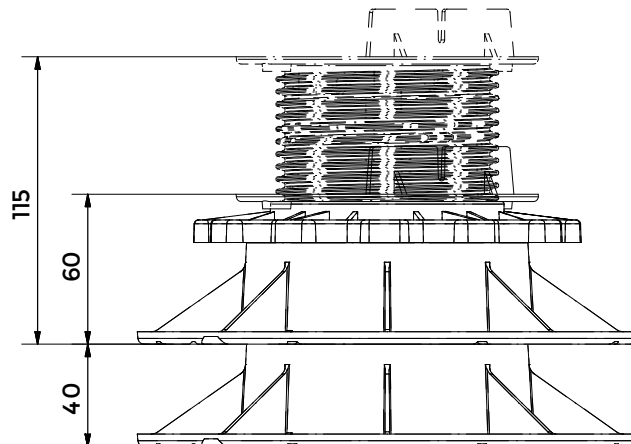
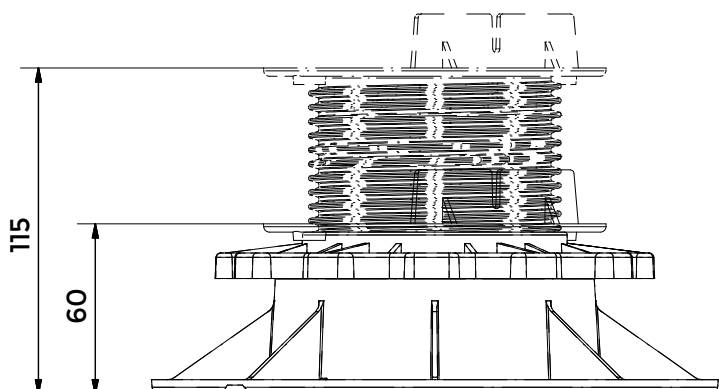

Each base has a special bottom shape that allows to be stack on another base.

ARKIMEDE 60 - DECKING

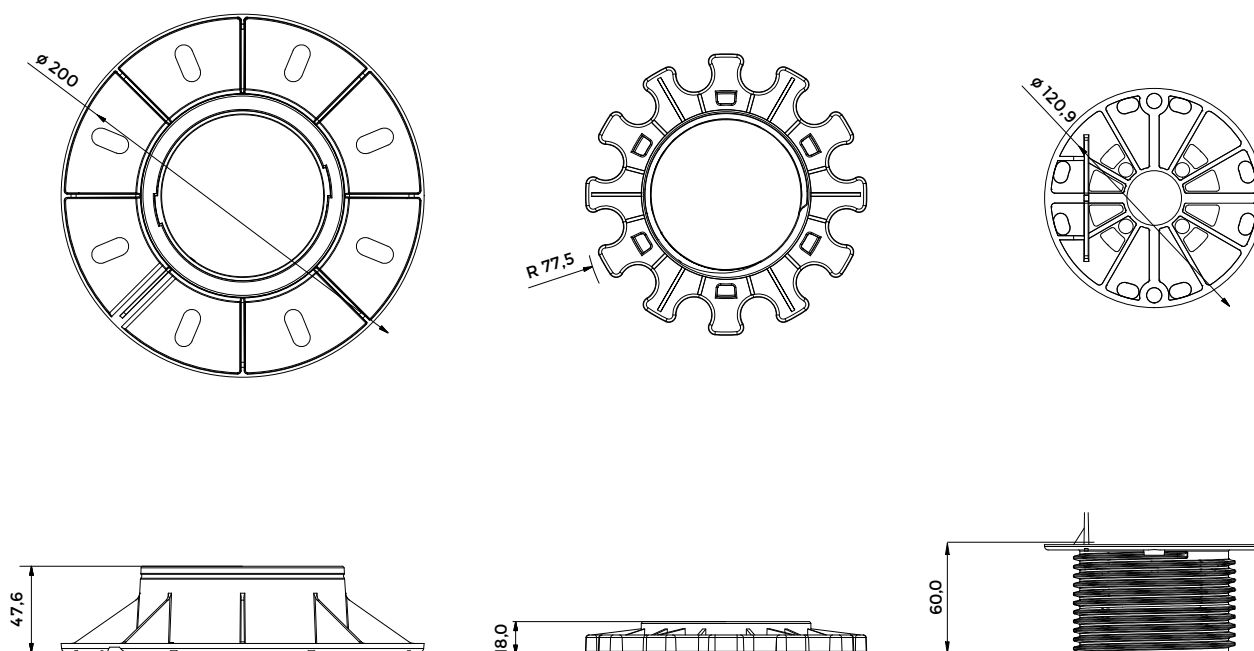

2. DESCRIPTION

Arkimede 60 support with adjustable height starting from 60 mm.
 Base laying surface: 314 cm². Head diameter: 120 mm with a laying surface of 113 cm².
 • Box composed by the base, rotating ring and head with 1 tab for joists.

The base allows the correct water drainage.
 • Extension h. 50 and 100 are available as an optional.

3. USE

Used in external areas, terraces, pavements.

Operating temperature: from - 40 ° C to + 80 ° C.

4. FIELDS OF USE

Waterproof membrane, hard insulating panels, screeds and solid and compact pose plans

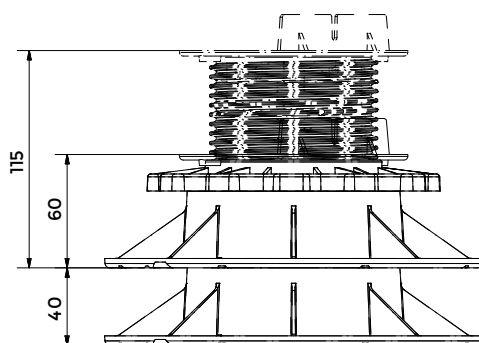

ARKIMEDE 60 - DECKING

5. LOAD TEST

TEST 1

| Code | Dimension | Max. Load [N] |
|-------|--------------|---------------|
| 30536 | h = 1.120 mm | 9.033 |

A punch of 150 mm diameter was used to carry out the test.

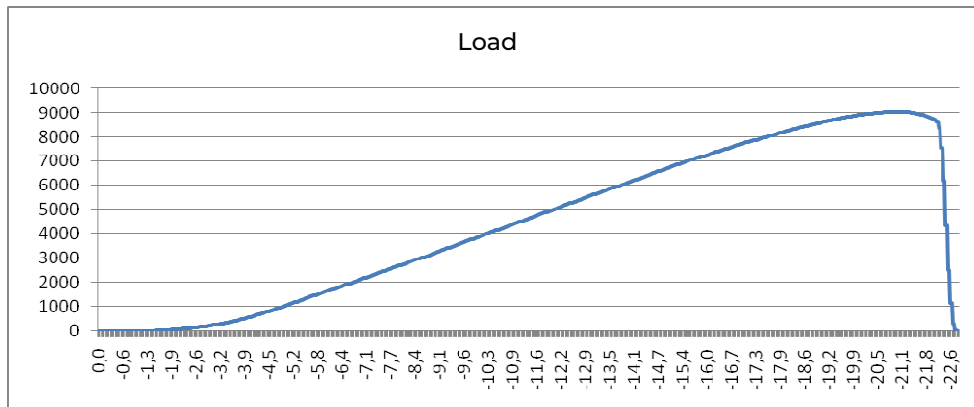

| | |
|----------------------|---------|
| Maximum Load | 9.033 N |
| Bend at Maximum Load | 21,0 mm |

TEST 2

| Code | Dimension | Max- Load [N] |
|-------|--------------|---------------|
| 30536 | h = 1.100 mm | 10.467 |

A punch of 150 mm diameter was used to carry out the test.

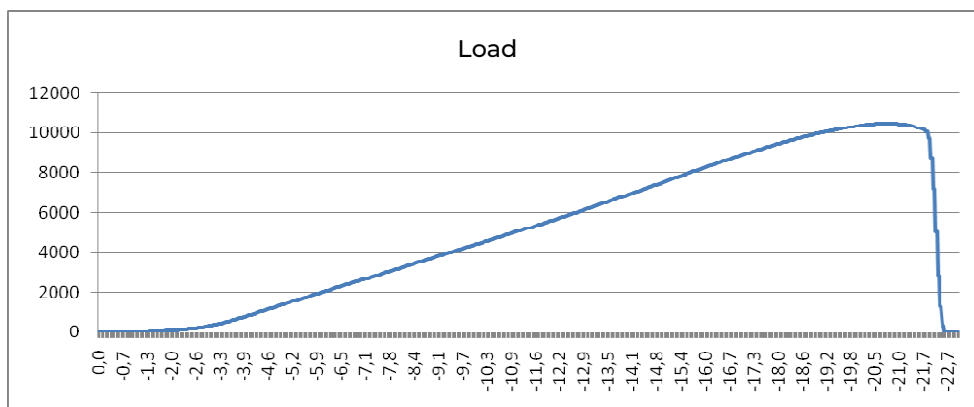

| | |
|----------------------|----------|
| Maximum Load | 10.467 N |
| Bend at Maximum Load | 20,7 mm |

6. TECHNICAL SPECIFICATION

| Specification | Description | Unity | Price |
|---------------|---|-------|-------|
| 30536 | Supply and installation of ARKIMEDE 60 - Decking support with adjustable height starting from 60 mm. Base laying surface: 314 cm ² . Head diameter: 120 mm with a laying surface of 113 cm ² . Available versions: · Box composed by the base, rotating nut and head with 1 tab for joists. The base allows the correct water drainage. Made of PP (polypropylene). Used in external areas, terraces, pavements. | pcs. | - |
| 30536 | 1 tab..... | pcs. | - |