

ARKIMEDE 35 - DECKING

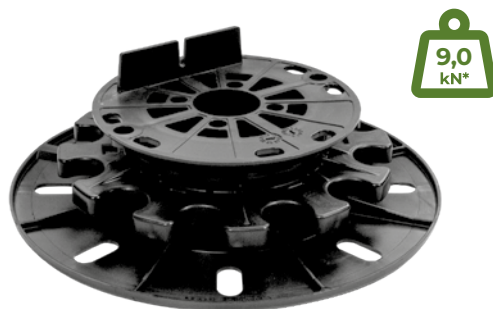

INDEX

1. Code registry
2. Description
3. Use
4. Fields of use
5. Load test
6. Technical specification

1. CODE REGISTRY

Code Adjustable Support	Product	Lenght (mm)	Weight (kg)	Pallet
30523	ARKIMEDE - fixed tab adjustable support	from 35 to 60	0,158	30 pcs. / 1.200 pcs..

MATERIAL Made of PP (polypropylene)

COLOUR Black

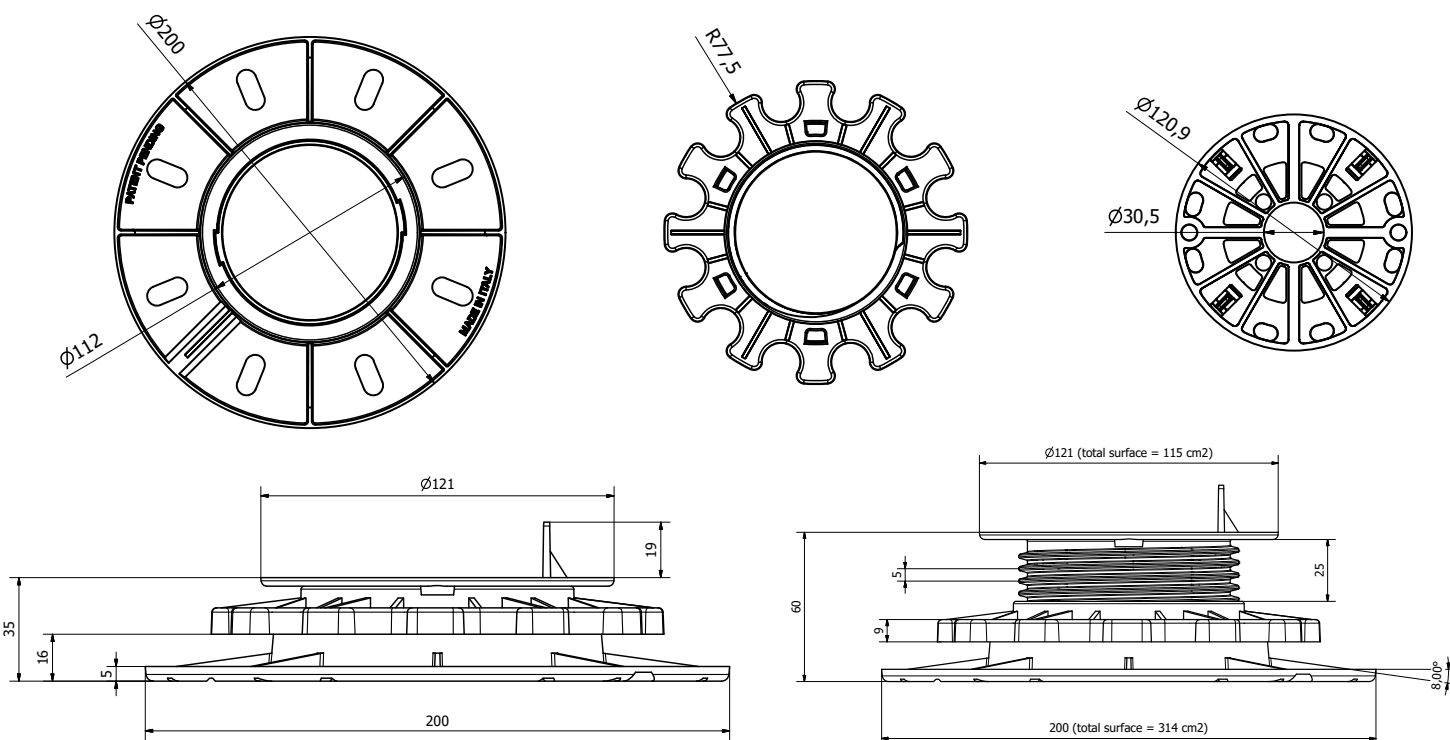

ARKIMEDE 35 - DECKING

2. DESCRIPTION

ARKIMEDE 35 support with adjustable height starting from 35 mm.
 Base laying surface: 314 cm².
 Head diameter: 120 mm with a laying surface of 113 cm².
 Available versions:
 · Box composed by the base, rotating nut and head with 1 tab for joists.
 The base allows the correct water drainage.
 Extension for adjustable support ARKIMEDE 35 with 25, 50, 100 mm height available.

3. USE

Use in outdoor areas, terraces, shared flooring
 Operating temperature: from - 40 ° C to + 80 ° C.

4. FIELDS OF USE

Waterproof membrane, hard insulating panels, screeds and solid and compact pose plans

5. LOADED TEST

Code	Dimensions	Max Load [N]
30523	h = 60 mm	10.409

A punch of 150 mm diameter was used to carry out the test.

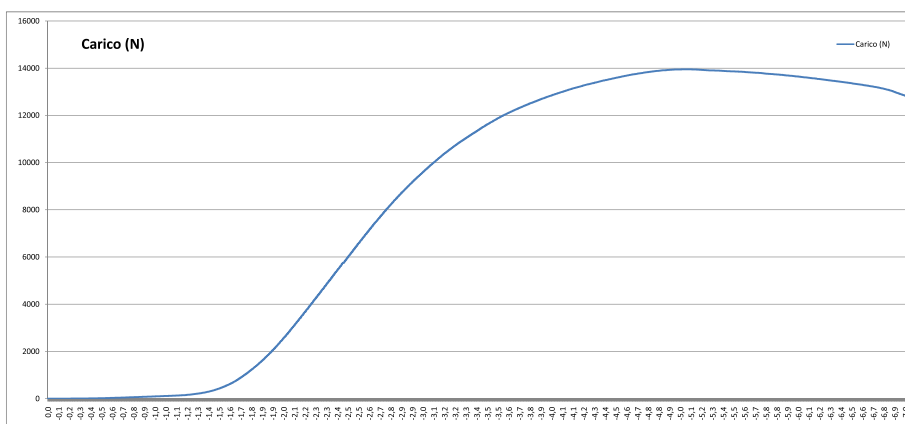

6. TECHNICAL SPECIFICATION

Specification	Description	Unity	Price
30523	Supply and intallation of adjustable support with adjustable height from min 35 to max 500 mm according to the matching accessories. Made of PP (polypropylene). Used in external areas, terraces, pavements.	pcs.	-
30523	1 tab.....	pcs.	-