





One Touch Push Opening and Soft Closing Slider

Installation Manual For Inner Net width Drawer 350-600mm

01 Pieze componente si specificatii

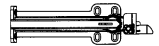
Denumire	Schita	Cantit
Mecanism OT piesa principala		1
Placuta montaj OT		1
Activator OT		1
Surub pal		4 pcs
Glisiera (set) -se achizitioneaza separat		1 set

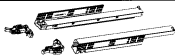
Disponibil pentru fronturi ale sertarului: 350-600mm
Test functionalitate : 50.000 de cicluri
Reglarea distantei intre panouri (gap) front-corp: 0-6 mm
Aplicare larga prin ajustarea fortei pe trei niveluri.

Capacitate de încărcare: 35 kg
Dimensiuni disponibile
pentru glisiera:
250-600 mm
Tip glisiera:
extensie completă fara
amortizare sau push-open
glisiera cu montaj sub sertar

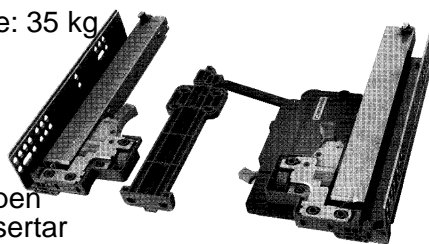

02 Cerinte de instalare sertar

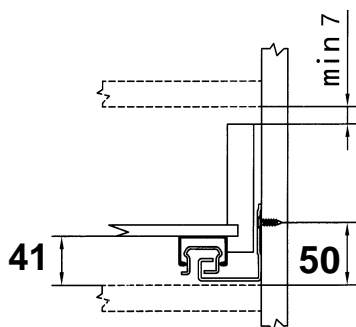

Sertar cu front aplicat / Sertar de interior(front incadrat)
SKW-latime neta interioara a sertarului
LW-latime neta interioara a corpului
T-grosimea panoului lateral

T	12-16	17-19
SKW	LW-42	LW-49

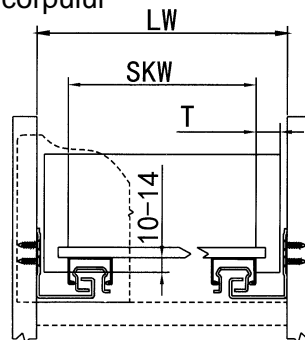

Sertar cu front aplicat
SKL-Lungime sertar/NL-Lungime nominala glisiera
SKL=NL-10

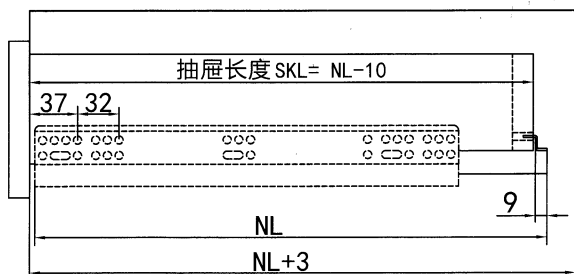

Sertar de interior(front incadrat)
SKL-Lungime sertar/NL-Lungime nominala glisiera
X-Grosimea panoului frontului sertarului

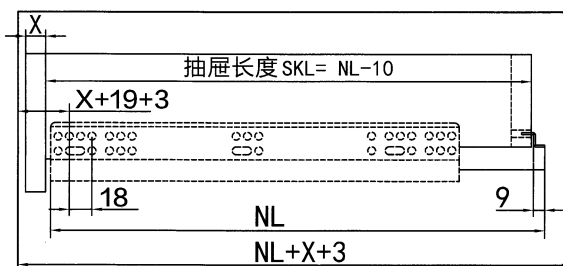

Cote instalare clips prindere glisiera si gaura pentru carlig

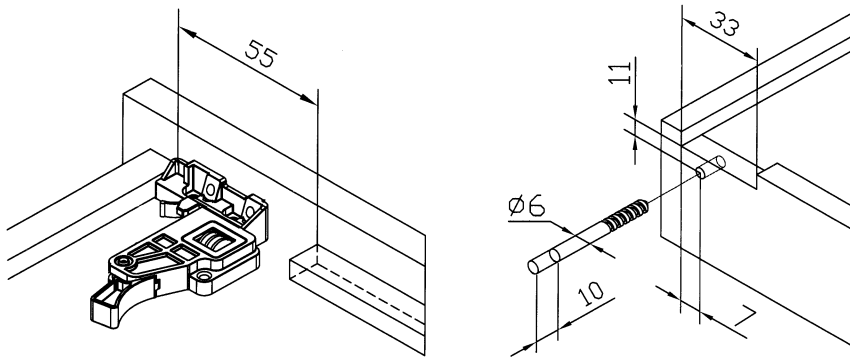

Cota de montaj activator

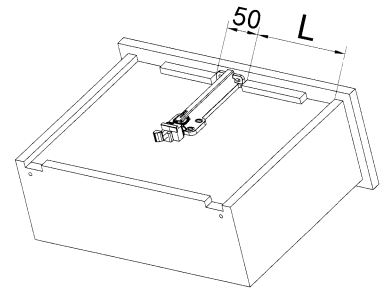

LW	350-450	450-600
L	165	200

03 Pasii de instalare

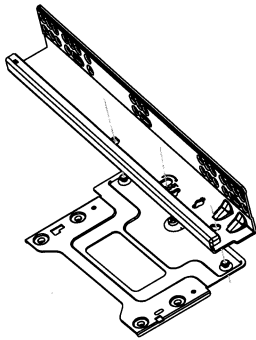

1. Montati placuta de montaj OT pe glisiera

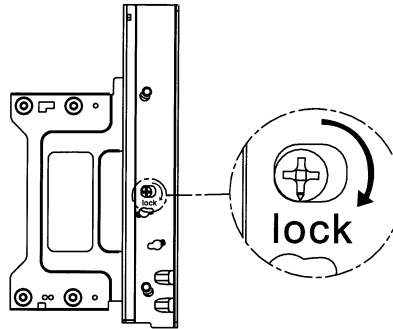

2. Rotiti surubul cu cama pentru blocarea placutei

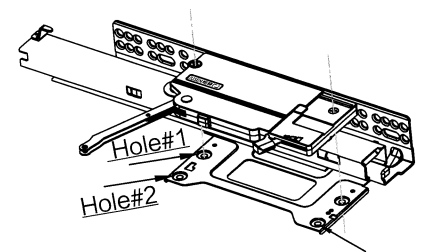

LW	350-450	450-600
Hole	1	2

3. Montati OT-ul pe placuta conform pozitiei celor doua gauri

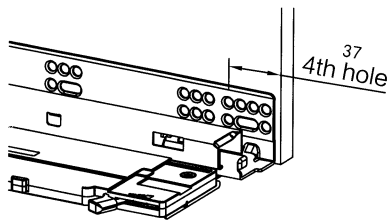

4. Montati glisiera pe corpul cabinetului

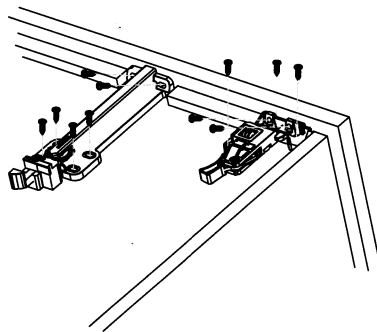

5. Montati clipsurile si activatorul pe fundul sertarului

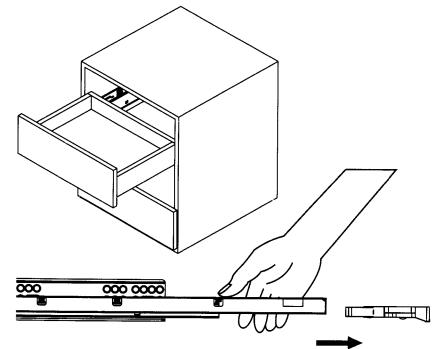

6. Fixati sertarul manual pe glisiera

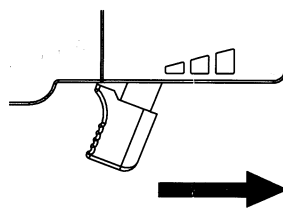
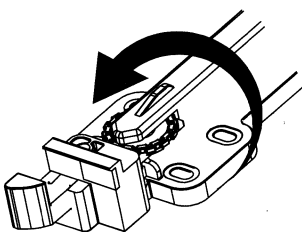

7. Reglati distanta frontului sertarului de corp (0-6mm). Nivelul de viteza se poate regla conform celor 3 trepte de ajustare