

## Parti componente / Components

1. Frana lant / Chain brake
2. Maner demaror / Starter handle
3. Carcasa filtru aer / Air filter cover
4. Buton clapeta aer (soc) / Choke lever
5. Buton siguranta acceleratie / Throttle trigger lockout
6. Maner posterior / Rear handle
7. Buton acceleratie / Throttle trigger
8. Carcasa posterioara / Rear case
9. Intrerupator On/Off / On/Off switch
10. Rezervor carburant / Fuel tank
11. Rezervor ulei / Oil tank
12. Maner frontal / Front handle
13. Lant / Saw chain
14. Sina de ghidare lant / Guide bar

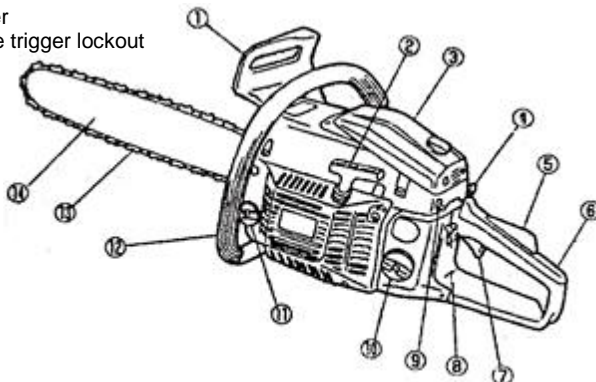

## Date tehnice / Technical data

Cod produs / Product's code	681167	681168
Tip motor / Engine	2 timpi, 1 cilindru racit cu aer 2 stroke, air cooled monocylinder	
Capacitate cilindrica / Displacement	58 cm <sup>3</sup>	
Putere maxima / Max power	3,3 CP	
Combustibil / Fuel	Amestec benzina fara Pb min 95 + ulei 2T* / Mix non-leaded gasoline min 95 + 2T oil*	
Proportie amestec combustibil / Fuel mix ratio	40 mL ulei 2T* la 1 L benzina / 40 mL 2T oil* mixed with 1 L gasoline	
Volum rezervor combustibil / Fuel tank volume	550 mL	
Ulei amestec* / Mix oil*	HGT ulei 2T* / HGT 2 stroke oil*	
Ulei lubrifiere lant** / Chain oil**	HGT ulei lubrifiere lant** / HGT chain oil**	
Volum rezervor ulei lubrifiere lant / Chain oil tank volume	260 mL	
Lungime sina ghidaj / Guide bar length	400 mm (16")	450 mm (18")
Pas lant / Chain pitch	0,325"	
Grosime canal / Gauge	1,5 mm	
Nivel de zgomot (LwA) / Sound power	114 dB(A), K = 3 dB(A)	
Nivel maxim de vibratii / Vibration max level	Fata / Front = 8,128 m/s <sup>2</sup> , K = 1,5 m/s <sup>2</sup> Spate / Rear = 7,235 m/s <sup>2</sup> , K = 1,5 m/s <sup>2</sup>	
Masa neta / Net weight	~ 6,7 kg	

\*Folositi numai ulei de amestec HGT destinat motoarelor in 2 timpi / Use only HGT oil designed for 2 stroke engines.

\*\*Folositi numai ulei HGT de lubrifiere a lantului / Use only HGT chain oil.